

PRO-FORM®

CARBON STRENGTH POWER RACK XL

Model No. PFBE45020.0

Serial No. _____

Write the serial number in the space above for reference.

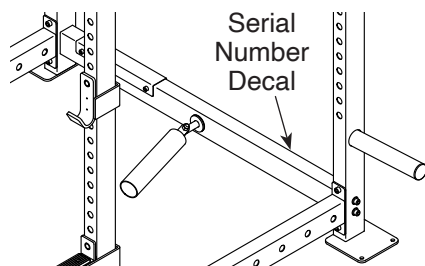

USER'S MANUAL

CUSTOMER CARE

UNITED KINGDOM

Call: 0330 123 1045

From Ireland: 053 92 36102

Website: iconsupport.eu

E-mail: csuk@iconeurope.com

Write:

ICON Health & Fitness, Ltd.

Unit 4, Westgate Court

Silkwood Park

OSSETT

WF5 9TT

UNITED KINGDOM

AUSTRALIA

Call: 1800 993 770

E-mail: australiacc@iconfitness.com

Write:

ICON Health & Fitness

PO Box 635

WINSTON HILLS NSW 2153

AUSTRALIA

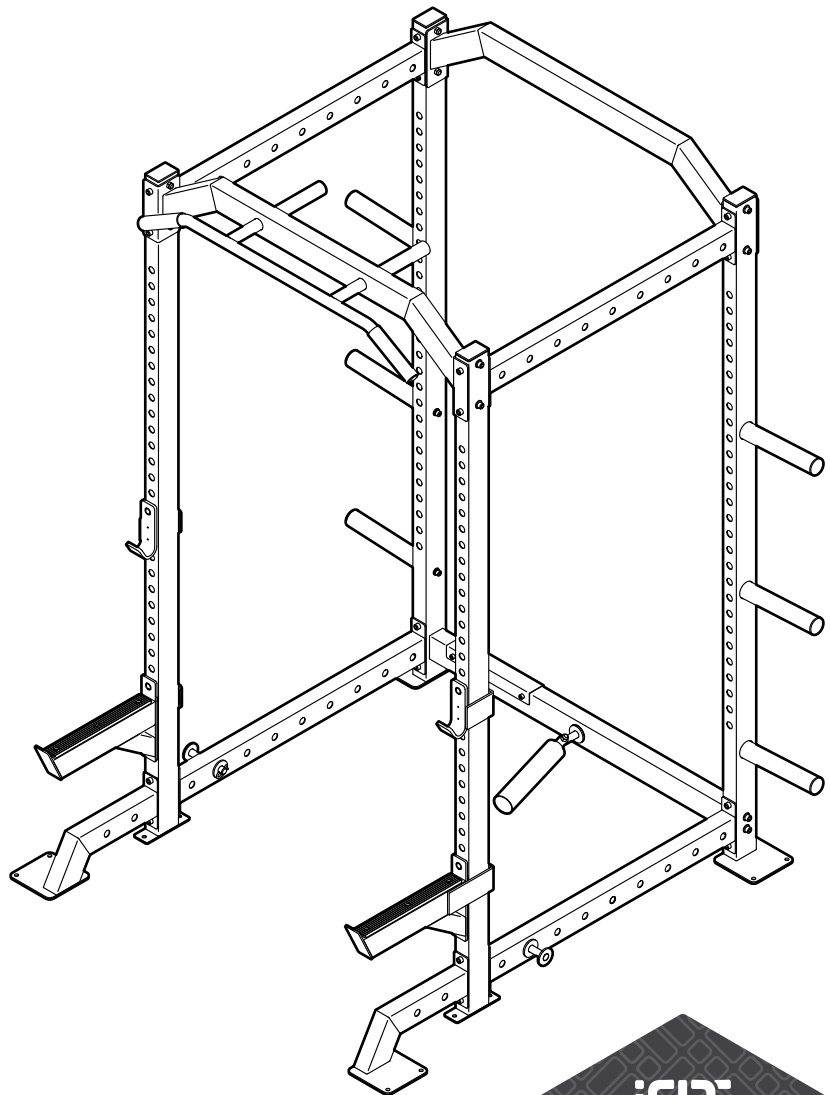

⚠ CAUTION

Read all precautions and instructions in this manual before using this equipment. Keep this manual for future reference.

iFIT

MAKE YOUR
FITNESS GOALS A
REALITY

IFIT.COM

TABLE OF CONTENTS

WARNING DECAL PLACEMENT	2
IMPORTANT PRECAUTIONS	3
BEFORE YOU BEGIN	5
PART IDENTIFICATION CHART	6
ASSEMBLY	7
ADJUSTMENT	12
EXERCISE GUIDELINES	13
PART LIST	14
EXPLODED DRAWING	15
ORDERING REPLACEMENT PARTS	Back Cover
LIMITED WARRANTY	Back Cover

WARNING DECAL PLACEMENT

The decals shown here have been applied to the rack. If a decal is missing or illegible, call the telephone number on the front cover of this manual and request a free replacement decal. Apply the decal in the location shown. Note: The decals may not be shown at actual size.

1

⚠ WARNING

DEATH OR SERIOUS CRIPPLING INJURY CAN OCCUR IF THE BARBELL DROPS SUDDENLY. TO AVOID INJURY, FOLLOW THESE PRECAUTIONS:

- BEFORE USING: Read all warnings and obtain instruction on the use of this machine.
- ALWAYS set both spotters when using machine.
- ALWAYS use a human spotter in addition to machine spotters.
- PROPER spotter height depends on the exercise performed. Adjust as follows:
 1. Remove all weight from the barbell.
 2. For squats, perform the exercise and determine the lowest comfortable position without your body contacting the floor. FOR SQUATS, NEVER PLACE THE SPOTTERS BELOW THE HEIGHT INDICATED ON THE MACHINE.
 For other exercises, perform the movement and select the lowest point of barbell travel without the barbell contacting your body.
- 3. Position both spotters to stop the barbell at this point. Ensure that both spotters are completely seated on the machine.
- 4. Load weights onto the barbell and carefully perform the exercise.

- Visually ensure the barbell latch is fully engaged and seated in the hooks before releasing the load and exiting the machine.
- DO NOT REMOVE this label. Replace when worn or damaged.

2

⚠ WARNING

User Weight maximum 300 lbs.
Weight Rest maximum 510 lbs.
Landmine maximum 150 lbs.
Weight Tube (each) maximum 150 lbs.

3

⚠ WARNING

HEAVY

Spotters must be used at all times.

4

⚠ WARNING

To reduce the risk of serious spinal injury, do not place spotters below this level when doing SQUAT exercises.

Spotters must be used at all times when this machine is used.

5

⚠ WARNING ⚠ ADVERTENCIA

- Misuse of this machine may result in serious injury.
- Read user's manual prior to use and follow all warnings and instructions.
- Do not allow children on or around machine.
- Keep body, clothing, and hair free and clear of all moving parts.
- Replace label if damaged, illegible, or removed.
- Mal uso de esta máquina puede resultar en graves lesiones
- Lea el manual del usuario antes del uso y siga todas las precauciones e instrucciones.
- No permita a los niños en o alrededor de la máquina.
- Mantenga el cuerpo, la ropa, y el pelo libres y alejados de todas las piezas móviles.
- Reemplace la calcomanía si está dañada, ilegible, o faltando.

6

⚠ WARNING

Risk of tipping;
bolt the rack to the floor if using bands.

IMPORTANT PRECAUTIONS

⚠️ WARNING: To reduce the risk of serious injury, read all important precautions and instructions in this manual and all warnings on the rack before using the rack. ICON assumes no responsibility for personal injury or property damage sustained by or through the use of this product.

1. It is the responsibility of the owner to ensure that all users of the rack are adequately informed of all precautions.
2. Before beginning any exercise program, consult your physician. This is especially important for persons over the age of 35 or persons with pre-existing health problems.
3. The rack is not intended for use by persons with reduced physical, sensory, or mental capabilities or lack of experience and knowledge, unless they are given supervision or instruction about the use of the rack by someone responsible for their safety.
4. Use the rack only as described in this manual.
5. The rack is intended for home use only. Do not use the rack in any commercial, rental, or institutional setting.
6. Keep the rack indoors, away from moisture and dust. Place the rack on a level surface, with a mat beneath it to protect the floor or carpet.
7. Make sure that there is enough clearance around the rack for the exercises that you will perform.
8. If you will use resistance bands (not included) with the rack, bolt the rack to the floor using the holes in the bases of the stabilizers and the rear uprights (see page 4 to identify the stabilizers and the rear uprights).
9. Inspect and properly tighten all parts each time the rack is used. Replace any worn parts immediately.
10. Keep children under age 16 and pets away from the rack at all times.
11. Wear appropriate clothes while exercising; do not wear loose clothes that could become caught on the rack. Always wear athletic shoes for foot protection.
12. The pull-up bar is designed to support a maximum user weight of 300 lbs. (136 kg). Do not place more than 510 lbs. (231 kg) of weight on the weight rests. Do not place more than 150 lbs. (68 kg) of weight, including a barbell and weights, in the landmine. Do not store more than 150 lbs. (68 kg) of weights on each weight tube. Note: The rack does not include a barbell or weights.
13. Keep hands and feet away from moving parts.
14. Over exercising may result in serious injury or death. If you feel faint, if you become short of breath, or if you experience pain while exercising, stop immediately and cool down.

BEFORE YOU BEGIN

Thank you for selecting the versatile PROFORM® CARBON STRENGTH POWER RACK XL rack. The rack offers a selection of exercise stations designed to develop the major muscle groups of the body. Whether your goal is to tone your body, build dramatic muscle size and strength, or improve your cardiovascular system, the rack will help you to achieve the specific results you want.

manual, please see the front cover of this manual. To help us assist you, note the product model number and serial number before contacting us. The model number and the location of the serial number decal are shown on the front cover of this manual.

Before reading further, please review the drawing below and familiarize yourself with the parts that are labeled.

For your benefit, read this manual carefully before using the rack. If you have questions after reading this

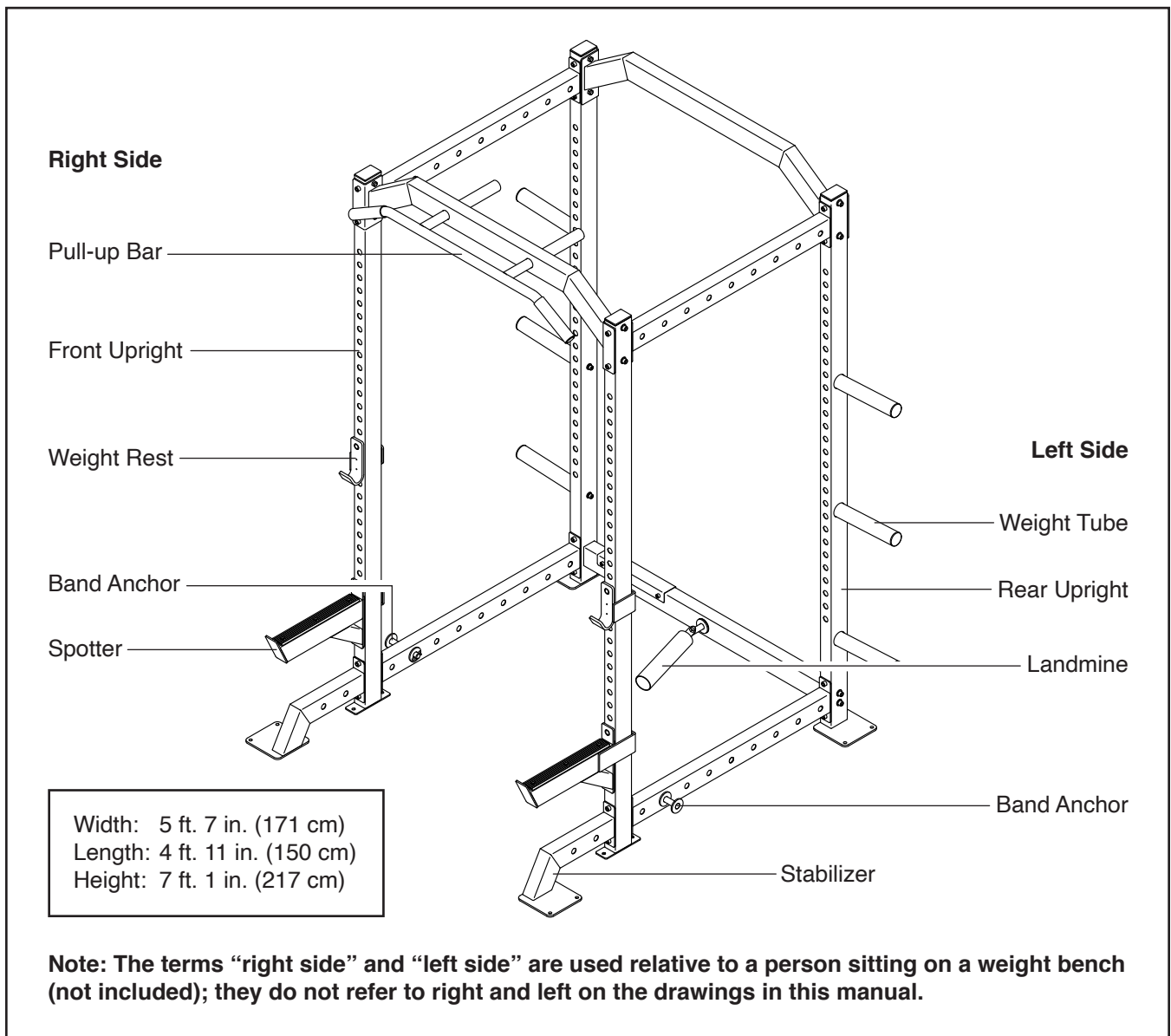

PART IDENTIFICATION CHART

Use the drawings below to identify the small parts needed for assembly. The number in parentheses below each drawing is the key number of the part, from the PART LIST near the end of this manual. The number following the key number is the quantity needed for assembly. **Note: If a part is not in the hardware kit, check to see whether it has been preassembled. Extra parts may be included.**

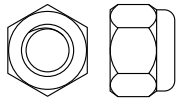

M8 Locknut
(29)-2

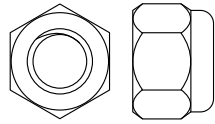

M10 Locknut
(27)-24



M10 Split
Washer
(22)-6

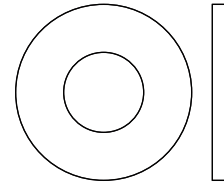

M10 Washer
(23)-22

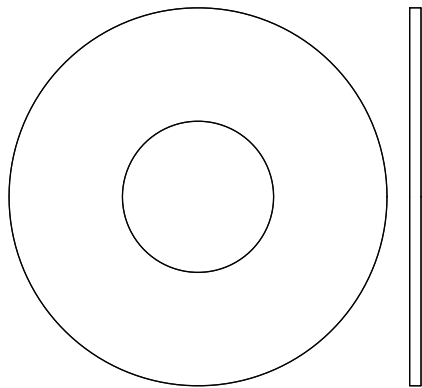

Nylon Washer
(3)-2

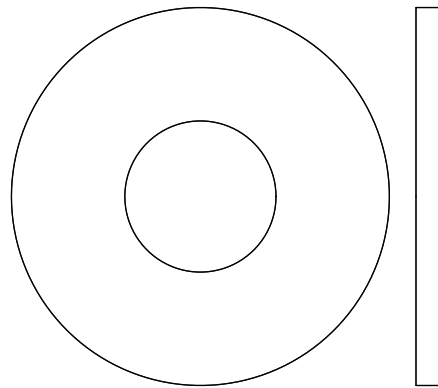

Large Washer
(4)-3

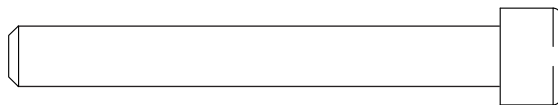

M8 x 65mm Bolt (28)-2

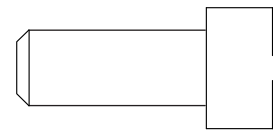

M10 x 25mm
Screw (26)-6

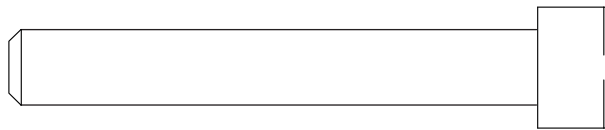

M10 x 70mm Bolt/Screw (24)-12

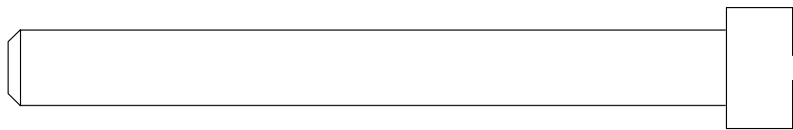

M10 x 95mm Bolt (25)-16

ASSEMBLY

- Assembly requires two persons.
- Because of its weight and size, assemble the rack in the location where it will be used. Make sure that there is enough clearance to walk around the rack.
- Place all parts in a cleared area and remove the packing materials. Do not dispose of the packing materials until assembly is finished.
- For help identifying small parts, see page 5.

- In addition to the included tool(s), assembly requires the following tool(s):

one adjustable wrench



one rubber mallet



Assembly may be easier if you have your own set of wrenches. To avoid damaging parts, do not use power tools.

1. **To Register your product and activate your warranty in the UK, go to iconsupport.eu.** If you do not have internet access, call Customer Service (see front cover of this manual)

To Register your product and activate your warranty in Australia, email or post the following information to the email address or postal address on the front cover of this manual

- your receipt(make sure to keep a copy)
- your name, address and telephone number
- the model number, serial number and name of your product (see the front cover of this manual)

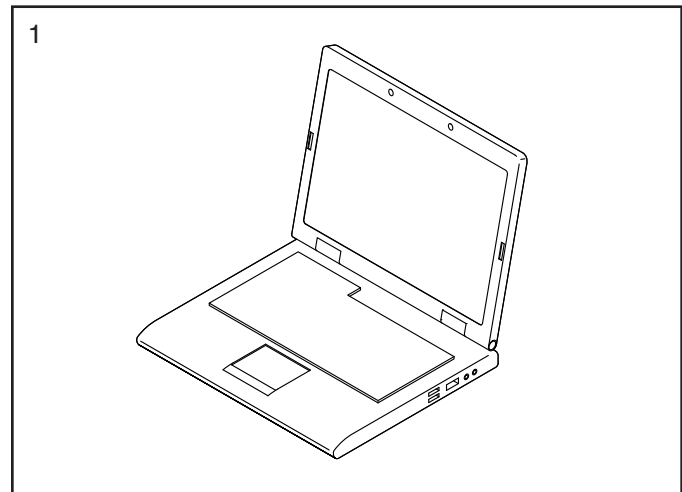

2. Identify a Rear Upright (10), and orient it so that the large holes (A) are on the side shown.

Attach a Side Crossbar (11) to the Rear Upright (10) with two M10 x 95mm Bolts (25), two M10 Washers (23), and two M10 Locknuts (27); **do not tighten the Locknuts yet.**

Attach a Side Crossbar (11) to the other Rear Upright (10) in the same way. Make sure that the large holes (A) are on the indicated side.

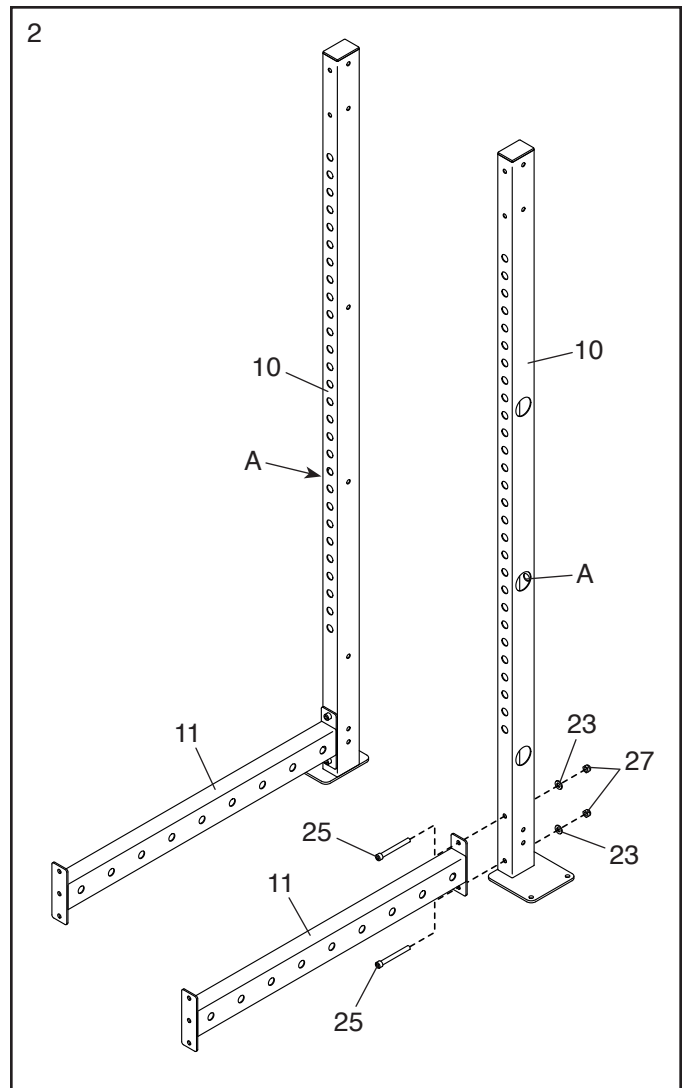

3. Identify the Left Stabilizer (33) and a Front Upright (12).

Attach the Left Stabilizer (33) and the Front Upright (12) to the indicated Side Crossbar (11) with two M10 x 95mm Bolts (25) and two M10 Locknuts (27); **do not tighten the Locknuts yet.**

Attach the Right Stabilizer (34) and the other Front Upright (12) to the other Side Crossbar (11) in the same way.

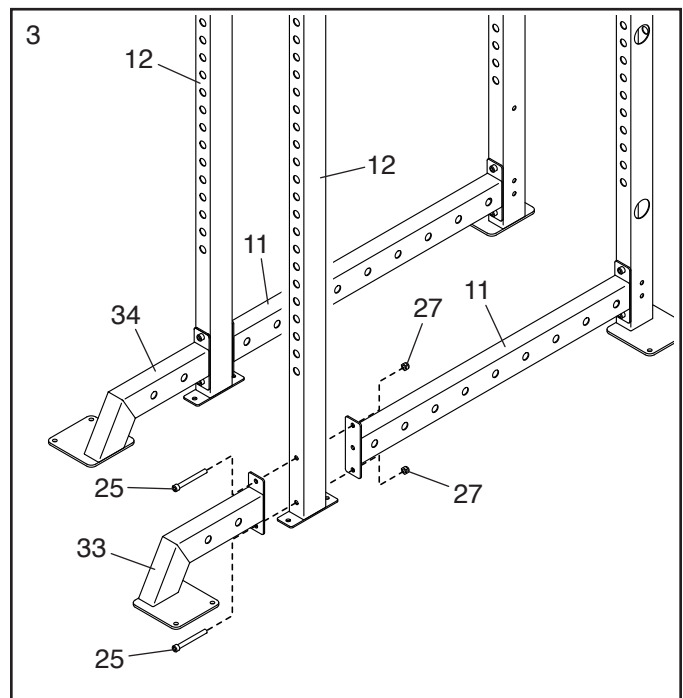

4. Orient the Rear Lower Crossbar (15) so that the small holes (B) are in the position shown.

Attach the Rear Lower Crossbar (15) to the left Rear Upright (10) with two M10 x 70mm Screws (24) and two M10 Washers (23); **do not tighten the Screws yet.**

Attach the Rear Lower Crossbar (15) to the right Rear Upright (10) in the same way.

See the inset drawing. Attach the Crossbar Cover (8) to the Rear Lower Crossbar (15) with two M8 x 65mm Bolts (28) and two M8 Locknuts (29).

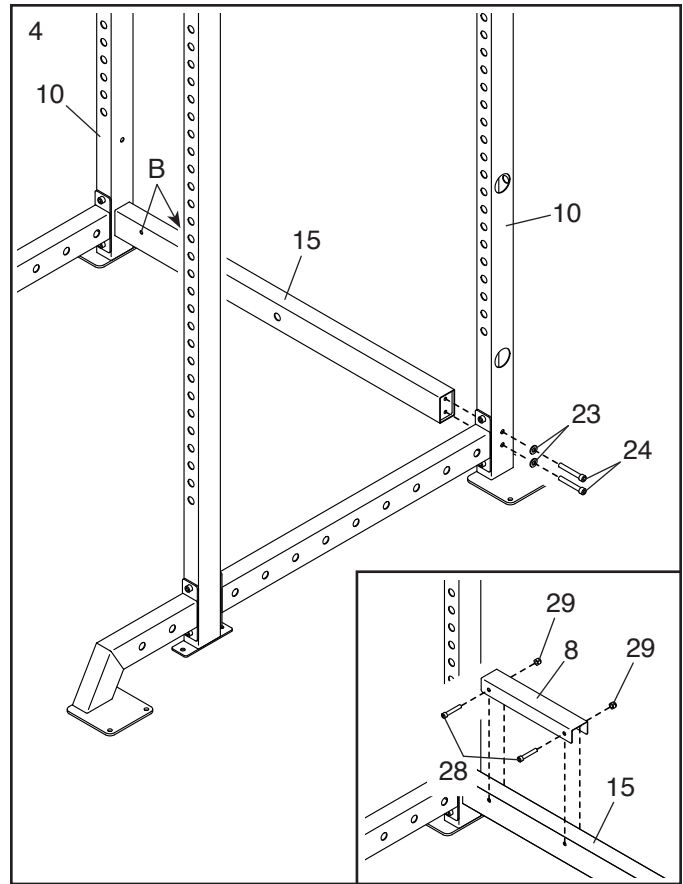

5. Hold the Rear Upper Crossbar (9) between the Rear Uprights (10).

Attach the Rear Upper Crossbar (9) to the left Rear Upright (10) with two M10 x 70mm Bolts (24), two M10 Washers (23), and two M10 Locknuts (27); **do not tighten the Locknuts yet.**

Then, attach the Rear Upper Crossbar (9) to the left upper Side Crossbar (11) with two M10 x 95mm Bolts (25) and two M10 Locknuts (27); **do not tighten the Locknuts yet.**

Attach the Rear Upper Crossbar (9) to the right Rear Upright (10) and to the right upper Side Crossbar (11) in the same way.

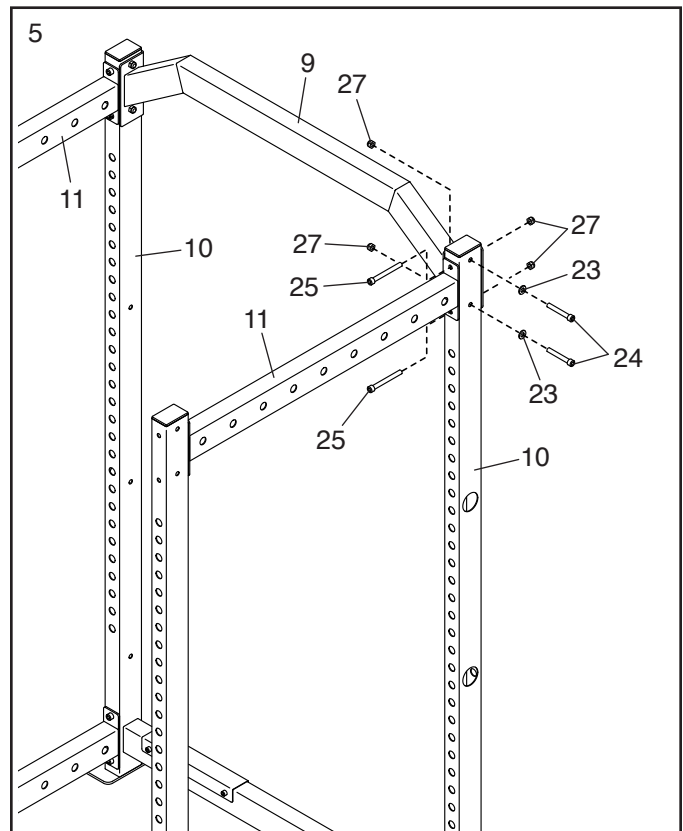

6. Hold the Front Crossbar (13) between the Front Uprights (12).

Attach the Front Crossbar (13) to the left Front Upright (12) with two M10 x 70mm Bolts (24), two M10 Washers (23), and two M10 Locknuts (27); **do not tighten the Locknuts yet.**

Then, attach the Front Crossbar (13) to the left upper Side Crossbar (11) with two M10 x 95mm Bolts (25) and two M10 Locknuts (27); **do not tighten the Locknuts yet.**

Attach the Front Crossbar (13) to the right Front Upright (12) and to the right upper Side Crossbar (11) in the same way.

See steps 2–6. Fully tighten the M10 Locknuts (27) and the M10 x 70mm Screws (24).

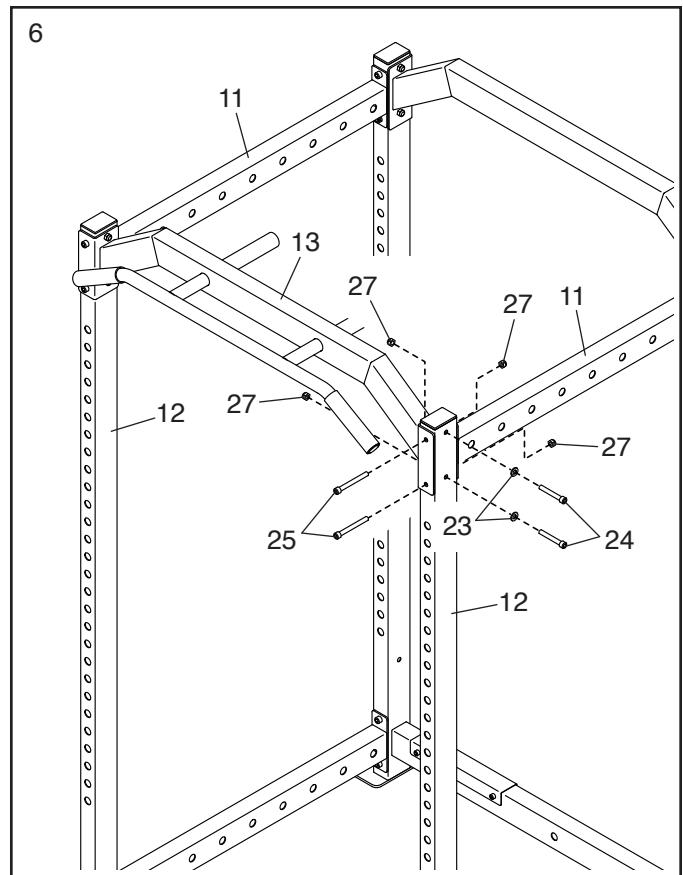

7. Attach a Weight Tube (14) to the left Rear Upright (10) with an M10 x 25mm Screw (26), an M10 Split Washer (22), and an M10 Washer (23).

Attach two more Weight Tubes (14) to the left Rear Upright (10) in the same way.

Attach the other three Weight Tubes (14) to the right Rear Upright (10) in the same way.

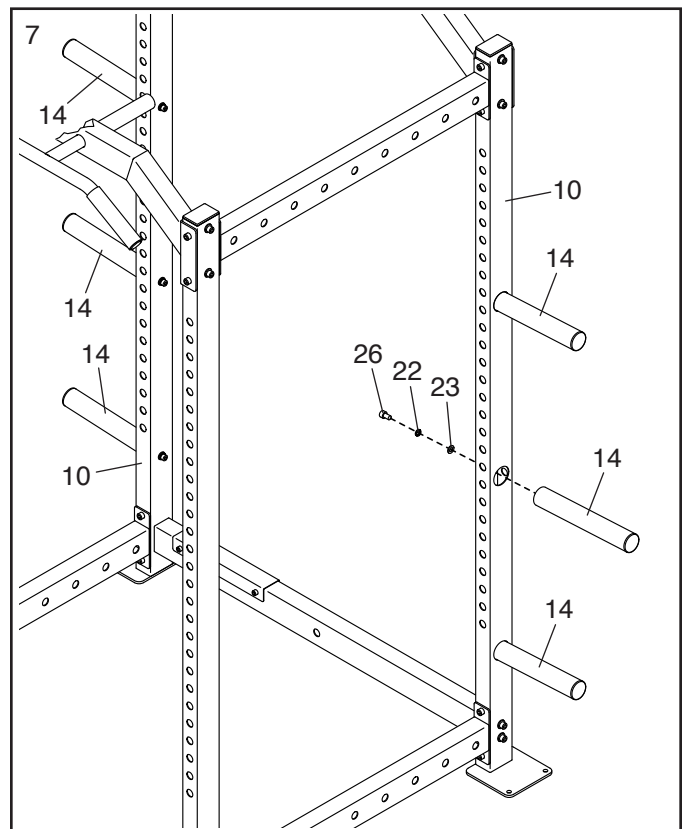

8. Slide a Nylon Washer (3) onto the Landmine Axle (2), and insert the Landmine Axle through the Rear Lower Crossbar (15).

Then, slide another Nylon Washer (3) and a Large Washer (4) onto the Landmine Axle (2), and insert a Cotter Pin (30) through the Landmine Axle.

Next, insert a Band Anchor (7) through one of the holes in the left lower Side Crossbar (11). Then, slide a Large Washer (4) onto the Band Anchor, and insert a Cotter Pin (30) through the Band Anchor.

Attach the other Band Anchor (7) to the right lower Side Crossbar (11) in the same way.

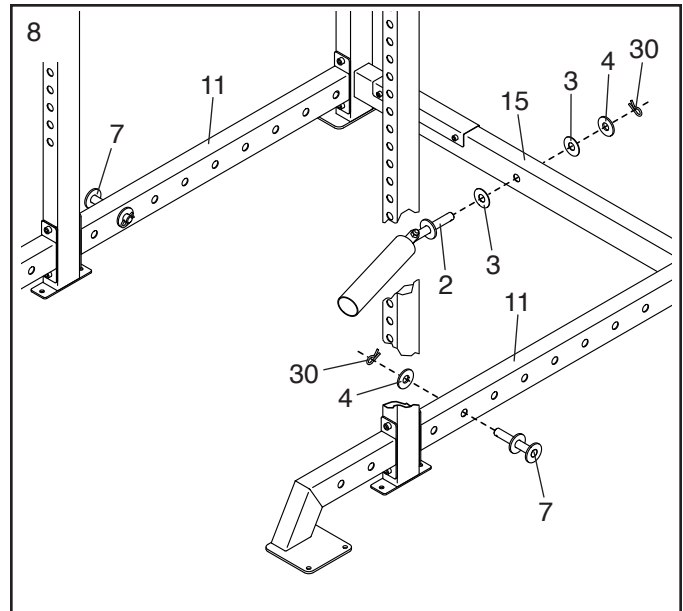

9. Identify the Left Weight Rest (5), insert it into one of the holes in the left Front Upright (12), and rotate it so that it is wrapped around the Front Upright.

Next, identify the Left Spotter (6), and attach it to the left Front Upright (12) in the same way.

Attach the Right Weight Rest (16) and the Right Spotter (17) to the right Front Upright (12) in the same way.

Make sure that both Weight Rests (5, 16) are at the same height and that both Spotters (6, 17) are at the same height.

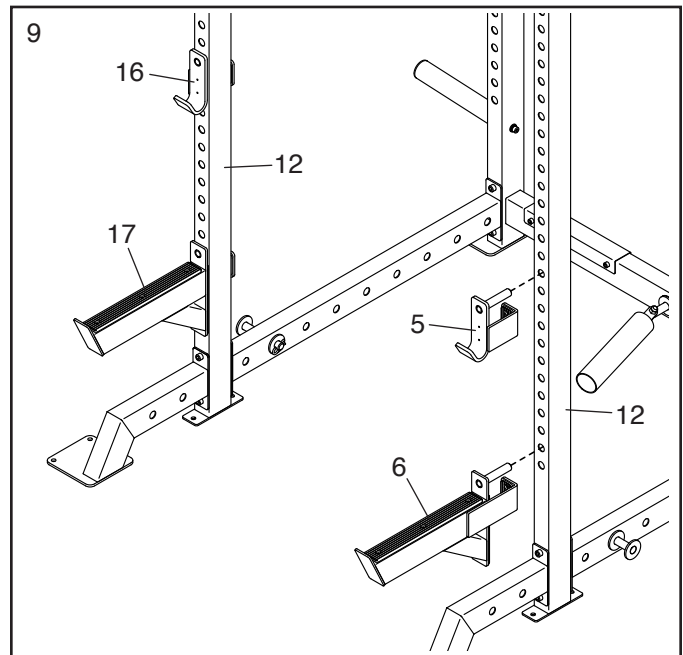

10. **Make sure that all parts are properly tightened before you use the rack.** Extra parts may be included. The use of all remaining parts will be explained in ADJUSTMENT on page 11.

ADJUSTMENT

This section explains how to adjust the rack. See the EXERCISE GUIDELINES on page 12 for important information about how to get the most benefit from your exercise program. **Make sure that all parts are properly tightened each time you use the rack. Replace any worn parts immediately.** The rack can be cleaned with a damp cloth and a mild, non-abrasive detergent; **do not use solvents.**

ADJUSTING THE WEIGHT RESTS AND THE SPOTTERS

To change the height of the Weight Rests (5, 16), remove them from the Front Uprights (12) and insert them into different holes in the Front Uprights. **Make sure to rotate the Weight Rests so that they are wrapped around the Front Uprights as shown.**

Adjust the Spotters (6, 17) in the same way.

⚠ WARNING: Make sure that both Weight Rests (5, 16) are at the same height and that both Spotters (6, 17) are at the same height. Do not place more than 510 lbs. (231 kg) on the Weight Rests.

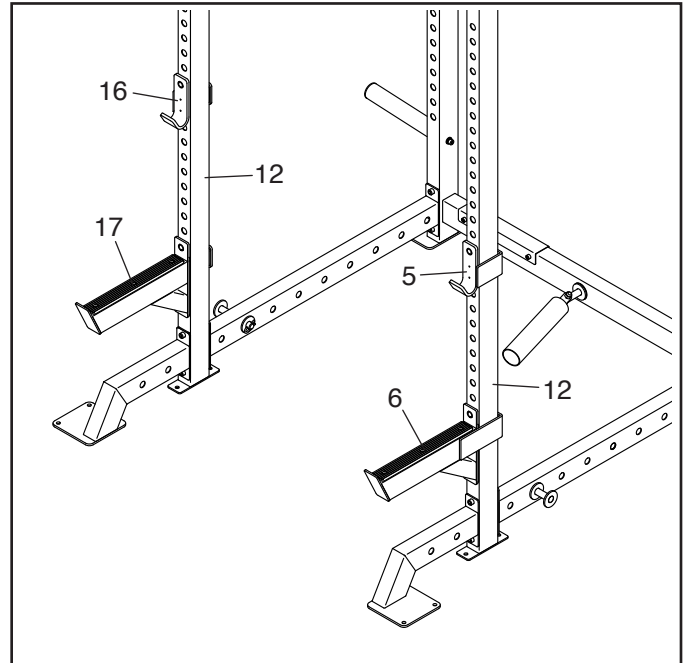

ADJUSTING THE LANDMINE AND THE BAND ANCHORS

To attach the Landmine (1) to the Rear Lower Crossbar (15) or to either of the lower Side Crossbars (11), see assembly step 8 on page 10.

⚠ WARNING: Do not place more than 150 lbs. (68 kg) of weight, including a barbell and weights, in the Landmine (1).

To attach the Band Anchors (7) to either of the lower Side Crossbars (11) or to the Stabilizers (33, 34), see assembly step 8 on page 10.

⚠ WARNING: Before using the Band Anchors (7), bolt the rack to the floor.

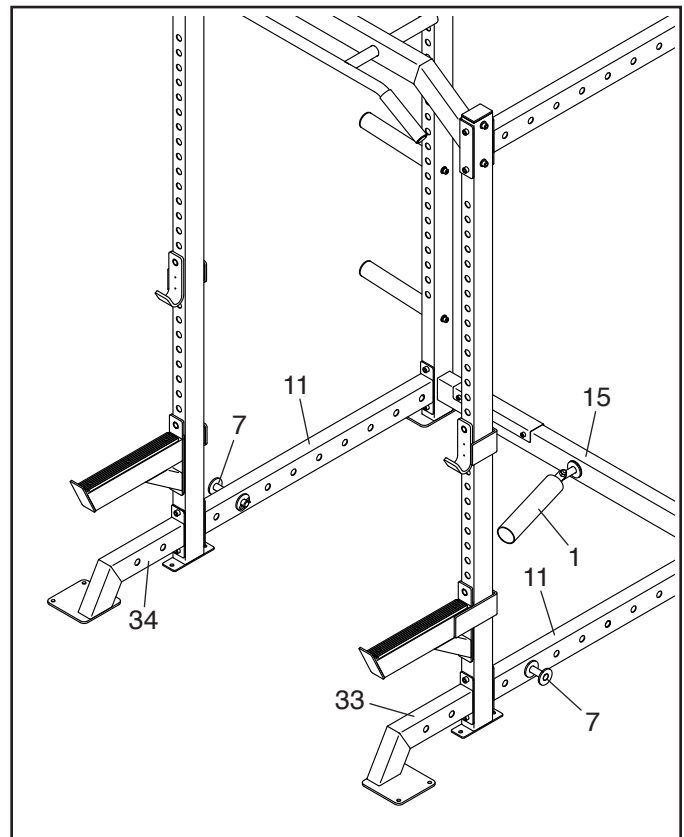

STORING YOUR WEIGHT PLATES

To store your weight plates (not included), slide them onto the Weight Tubes (14).

⚠ WARNING: Do not place more than 150 lbs. (68 kg) of weight on each Weight Tube (14).

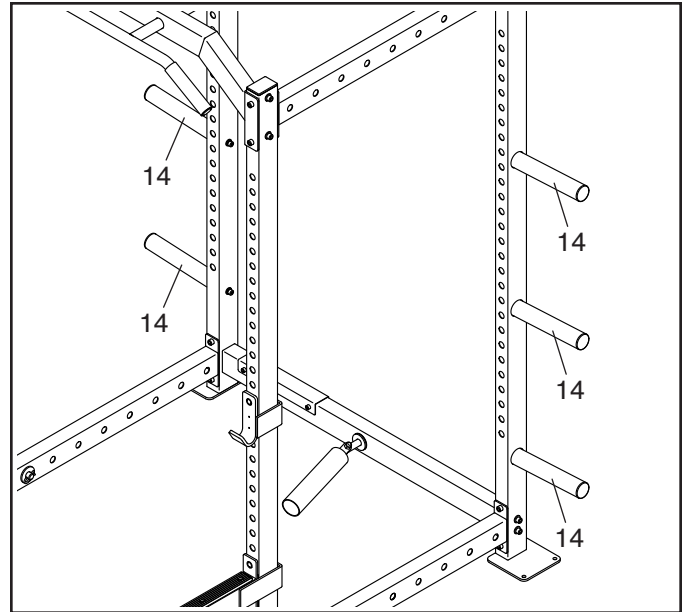

EXERCISE GUIDELINES

FOUR TYPES OF STRENGTH WORKOUTS

Note: A “repetition” is one complete cycle of an exercise, such as one sit-up. A “set” is a series of repetitions.

Muscle Building—Work your muscles near their maximum capacity and progressively increase the intensity of your exercise. Adjust the intensity level of an individual exercise as follows:

- Change the amount of resistance used.
- Change the number of repetitions or sets performed.

Use your own judgment to determine the amount of resistance that is right for you. Begin with 3 sets of 8 repetitions for each exercise you perform. Rest for 3 minutes after each set. When you can complete 3 sets of 12 repetitions without difficulty, increase the amount of resistance.

Toning—Tone your muscles by working them to a moderate percentage of their capacity. Select a moderate amount of resistance and increase the number of repetitions in each set. Complete as many sets of 15 to 20 repetitions as possible without discomfort. Rest for 1 minute after each set. Work your muscles by completing more sets rather than by using high amounts of resistance.

Weight Loss—To lose weight, use a low amount of resistance and increase the number of repetitions in each set. Exercise for 20 to 30 minutes, resting for a maximum of 30 seconds between sets.

Cross Training—Combine strength training and aerobic exercise by following this type of program:

- Strength training workouts on Monday, Wednesday, and Friday.
- 20 to 30 minutes of aerobic exercise on Tuesday and Thursday.
- One full day of rest each week to give your body time to regenerate.

WORKOUT GUIDELINES

Familiarize yourself with the equipment and learn the proper form for each exercise. Use your own judgment to determine the appropriate length of time for each workout, and the numbers of repetitions and sets to complete. Progress at your own pace and be sensitive to your body’s signals. Follow each workout with at least one day of rest.

Warming Up—Start with 5 to 10 minutes of stretching and light exercise. A warm-up increases your body temperature, heart rate, and circulation in preparation for exercise.

Working Out—Include 6 to 10 different exercises in each workout. Select exercises for every major muscle group, emphasizing areas that you want to develop. To give balance and variety to your workouts, vary the exercises from workout to workout.

Cooling Down—Finish with 5 to 10 minutes of stretching. Stretching increases the flexibility of your muscles and helps to prevent post-exercise problems.

EXERCISE FORM

Move through the full range of motion for each exercise and move only the appropriate parts of the body. Perform the repetitions in each set smoothly and without pausing. The exertion stage of each repetition should last about half as long as the return stage.

Exhale during the exertion stage of each repetition and inhale during the return stroke. Never hold your breath.

Rest for a short period of time after each set:

- Muscle Building—Rest for three minutes after each set.
- Toning—Rest for one minute after each set.
- Weight Loss—Rest for 30 seconds after each set.

STAYING MOTIVATED

For motivation, keep a record of each workout. Write the date, the exercises performed, the resistance used, and the numbers of sets and repetitions completed. Record your weight and key body measurements once a month. To achieve good results, make exercise a regular and enjoyable part of your life.

PART LIST

Model No. PFBE45020.0 R0720A

Key No.	Qty.	Description	Key No.	Qty.	Description
1	1	Landmine	19	6	Large Round Cap
2	1	Landmine Axle	20	4	Small Round Cap
3	2	Nylon Washer	21	2	Bushing
4	3	Large Washer	22	6	M10 Split Washer
5	1	Left Weight Rest	23	22	M10 Washer
6	1	Left Spotter	24	12	M10 x 70mm Bolt/Screw
7	2	Band Anchor	25	16	M10 x 95mm Bolt
8	1	Crossbar Cover	26	6	M10 x 25mm Screw
9	1	Rear Upper Crossbar	27	25	M10 Locknut
10	2	Rear Upright	28	2	M8 x 65mm Bolt
11	4	Side Crossbar	29	2	M8 Locknut
12	2	Front Upright	30	3	Cotter Pin
13	1	Front Crossbar	31	1	M10 x 60mm Bolt
14	6	Weight Tube	32	4	Grip
15	1	Rear Lower Crossbar	33	1	Left Stabilizer
16	1	Right Weight Rest	34	1	Right Stabilizer
17	1	Right Spotter	*	—	User's Manual
18	4	Rectangle Cap			

Note: Specifications are subject to change without notice. For information about ordering replacement parts, please see the back cover of this manual. *These parts are not illustrated.

EXPLODED DRAWING

Model No. PFBE45020.0 R0720A

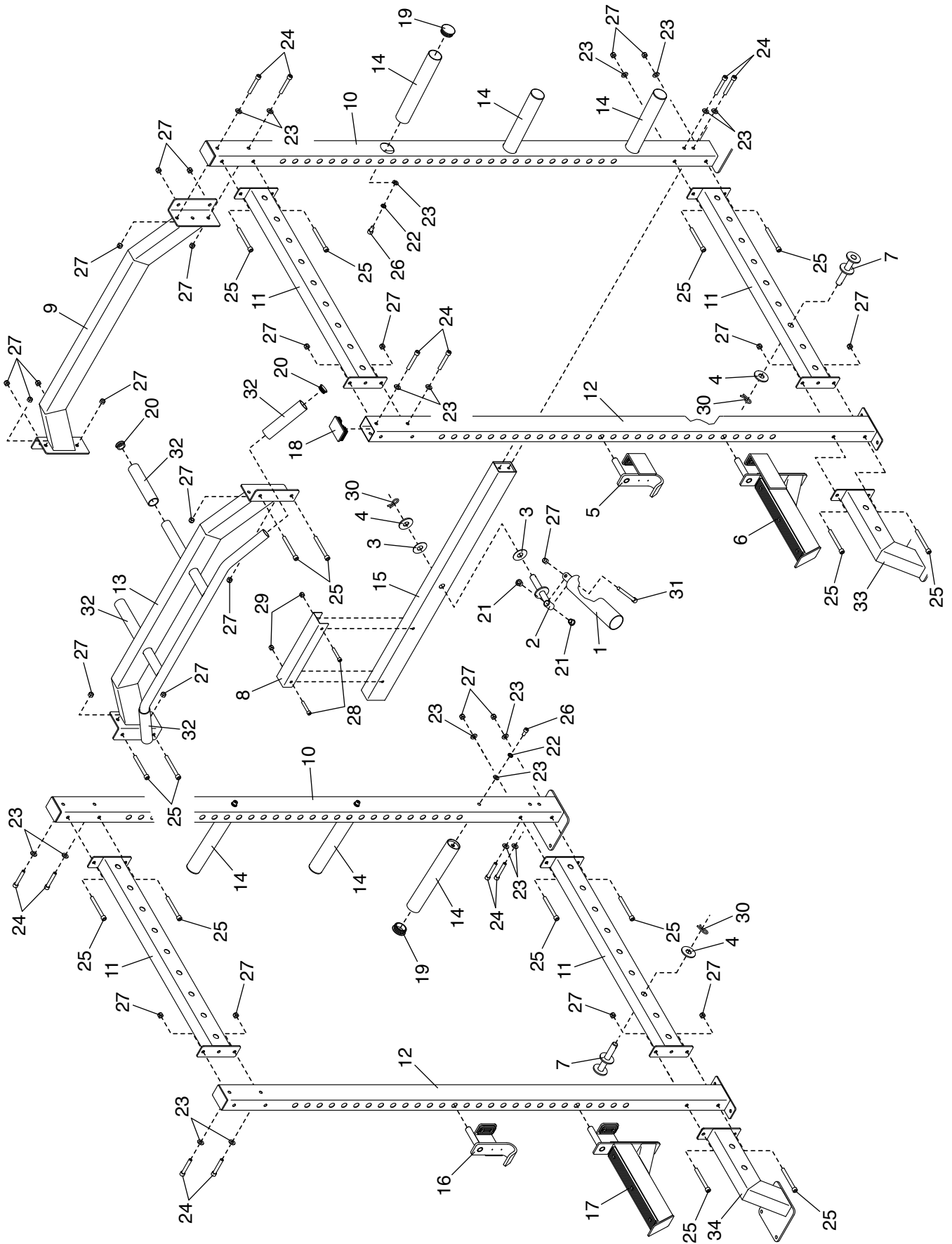

ORDERING REPLACEMENT PARTS

To order replacement parts, please see the front cover of this manual. To help us assist you, be prepared to provide the following information when contacting us:

- the model number and serial number of the product (see the front cover of this manual)
- the name of the product (see the front cover of this manual)
- the key number and description of the replacement part(s) (see the PART LIST and the EXPLODED DRAWING near the end of this manual)