

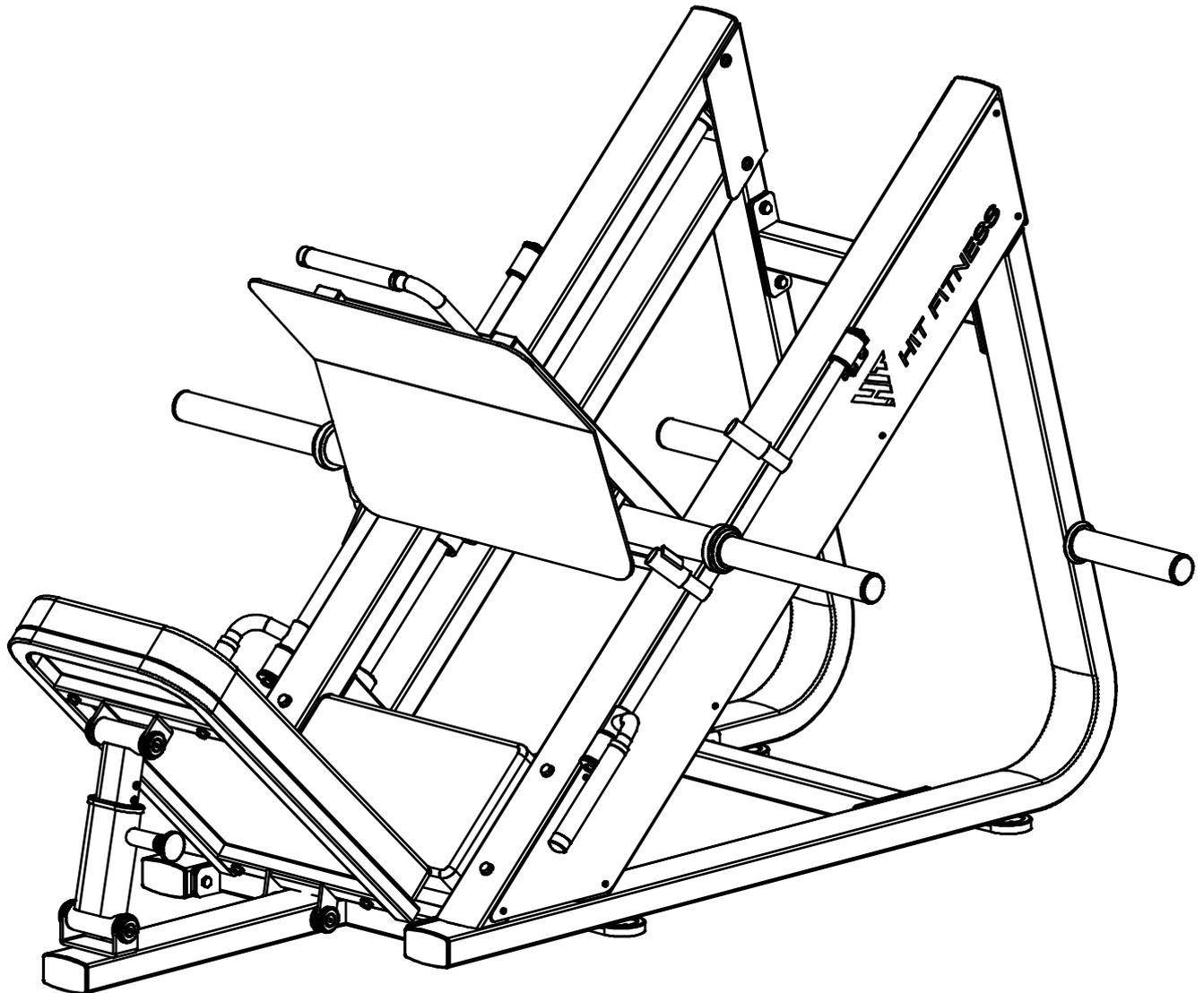

**HIT FITNESS**

**Hit Fitness Comm Leg Press**

**HIT00747**



# EXPLOSIVE VIEW

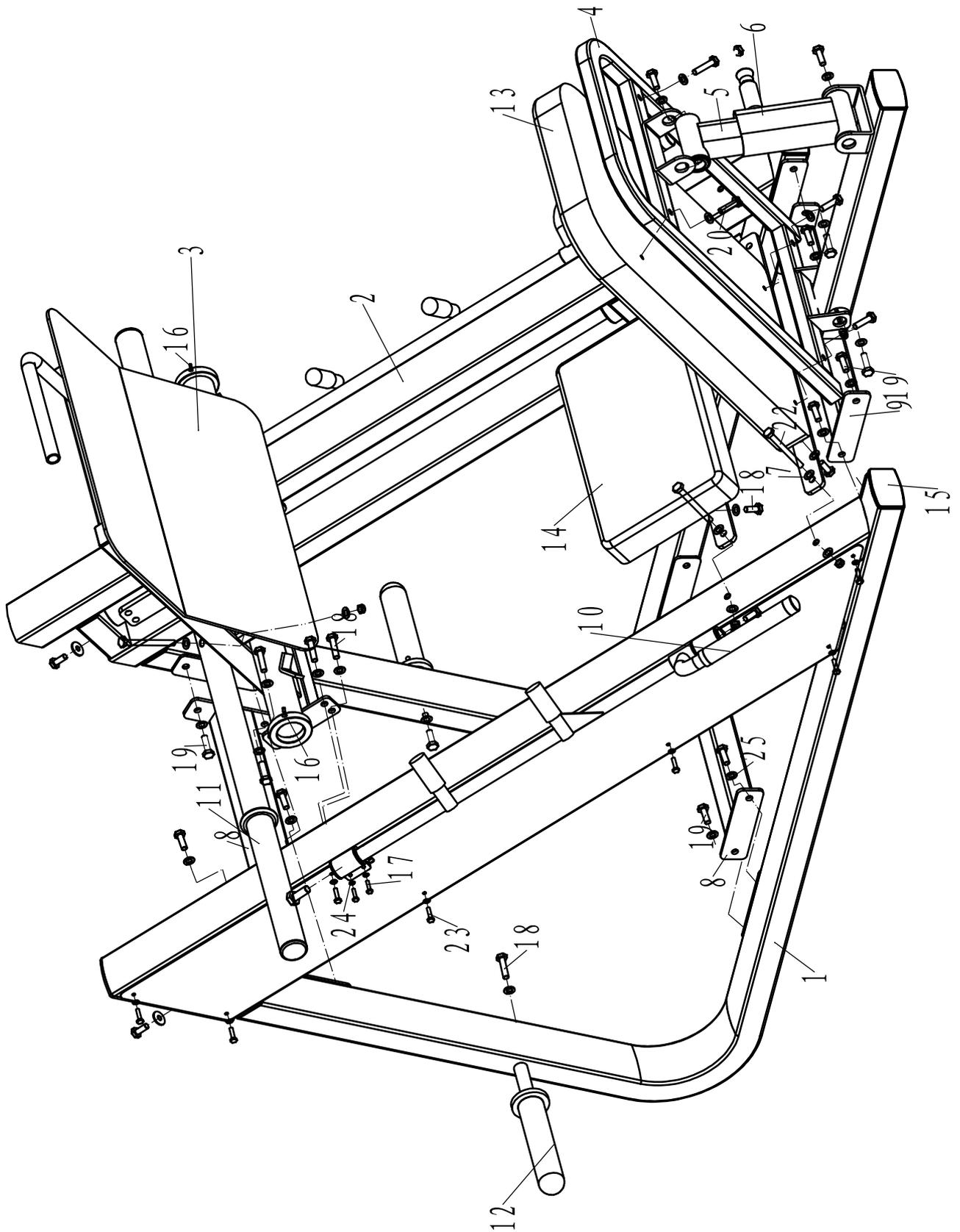

## COMPONENT LIST

ITEM NO.	DESCRIPTION	QTY.
1	Right bottom frame	1
2	Left bottom frame	1
3	Sliding frame	1
4	Back pad frame	1
5	Back pad adjusting frame	1
6	Back pad adjusting fixed frame	1
7	Back pad fixed plate	2
8	Contacting crossbar	2
9	Back pad frame contacting frame	1
10	Handlebar	2
11	Barbell bar	1
12	Bell hanging bar	2
13	Pour kicking back pad	1
14	Block pad	1
15	GJ plug	3
16	M8*8 Fasten screw	2
17	M8*15 Allen head bolt	4
18	M10*20 Allen head bolt	14
19	M10*25 Allen head bolt	20
20	M10*40 Allen head bolt	4
21	M10*75 Allen head bolt	1
22	M10*80 Allen head bolt	4
23	M4.8*35 Screw	16
24	Φ 8 Washer	4
25	Φ 10 Washer	40
26	Φ 10 Arc washer	2
27	M10 Nylon nut	1

## HARDWARE LIST 1

ITEM NO.	DESCRIPTION	QTY.
18	M10*20 Allen head bolt	14
19	M10*25 Allen head bolt	12
20	M10*40 Allen head bolt	4
21	M10*75 Allen head bolt	1
22	M10*80 Allen head bolt	4
25	Φ 10 Washer	34
26	Φ 10 Arc washer	2
27	M10 Nylon nut	5

## HARDWARE LIST 2

ITEM NO.	DESCRIPTION	QTY.
T1	4# Fork wrench	1
T2	17-14 Fork wrench	2
	Butterfly clip	2
	Lubricant	1

### ASSEMBLY INSTRUCTION:

#### Step 1:

Fix Contacting crossbar 8 and Back pad frame contacting frame 9 to Right bottom frame 1 and Left bottom frame 2 with M10 \* 25 Allen head bolt 19 and  $\Phi 10$  Washer 25.

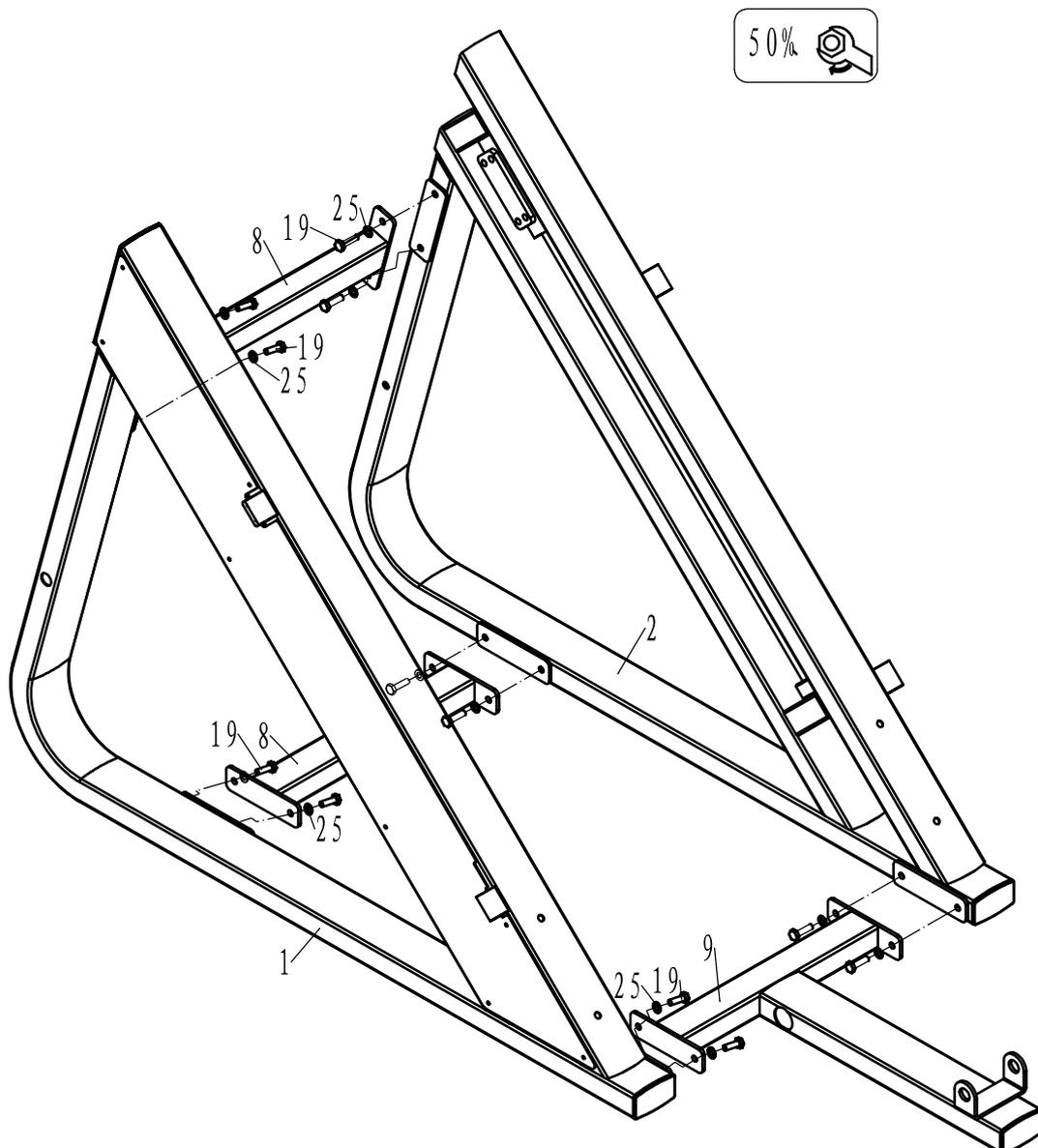

**Step2:**

Fix Sliding frame3 to Right bottom frame1 and Left bottom frame2 with M10 \* 20 Allen head bolt18 and  $\Phi$  10 Washer25.

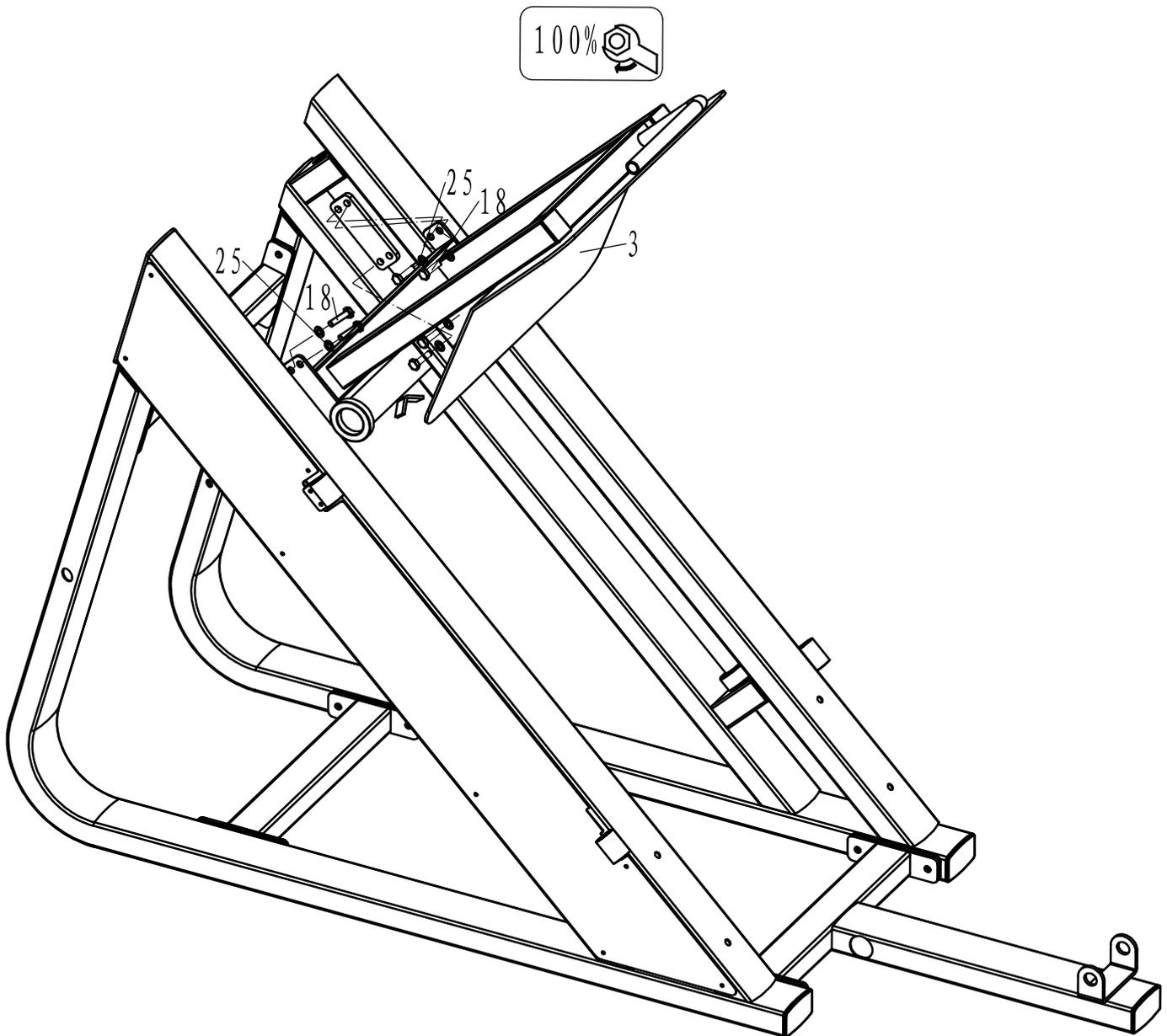

### Step3:

- 1.First insert Fix Barbell bar11 to sleeve, fix Barbell bar11 to Sliding frame3 with M10 \* 75 Allen head bolt21 and  $\Phi$  10 Arc washer26,then fix Barbell bar11 to Right bottom frame1 and Left bottom frame2 with  $\Phi$  10 Arc washer26, M10 Nylon nut and M8\*8 Fasten screw16.
- 2.Fix Back pad fix plate7 to Right bottom frame1 and Left bottom frame2 with M10 \* 80 Allen head bolt22,  $\Phi$  10 Washer25 and M10 Nylon nut27.
- 3.Fix Barbell hanging bar12 to Right bottom frame1 and Left bottom frame2 with M10 \* 20 Allen head bolt18 and  $\Phi$  10 Washer25.

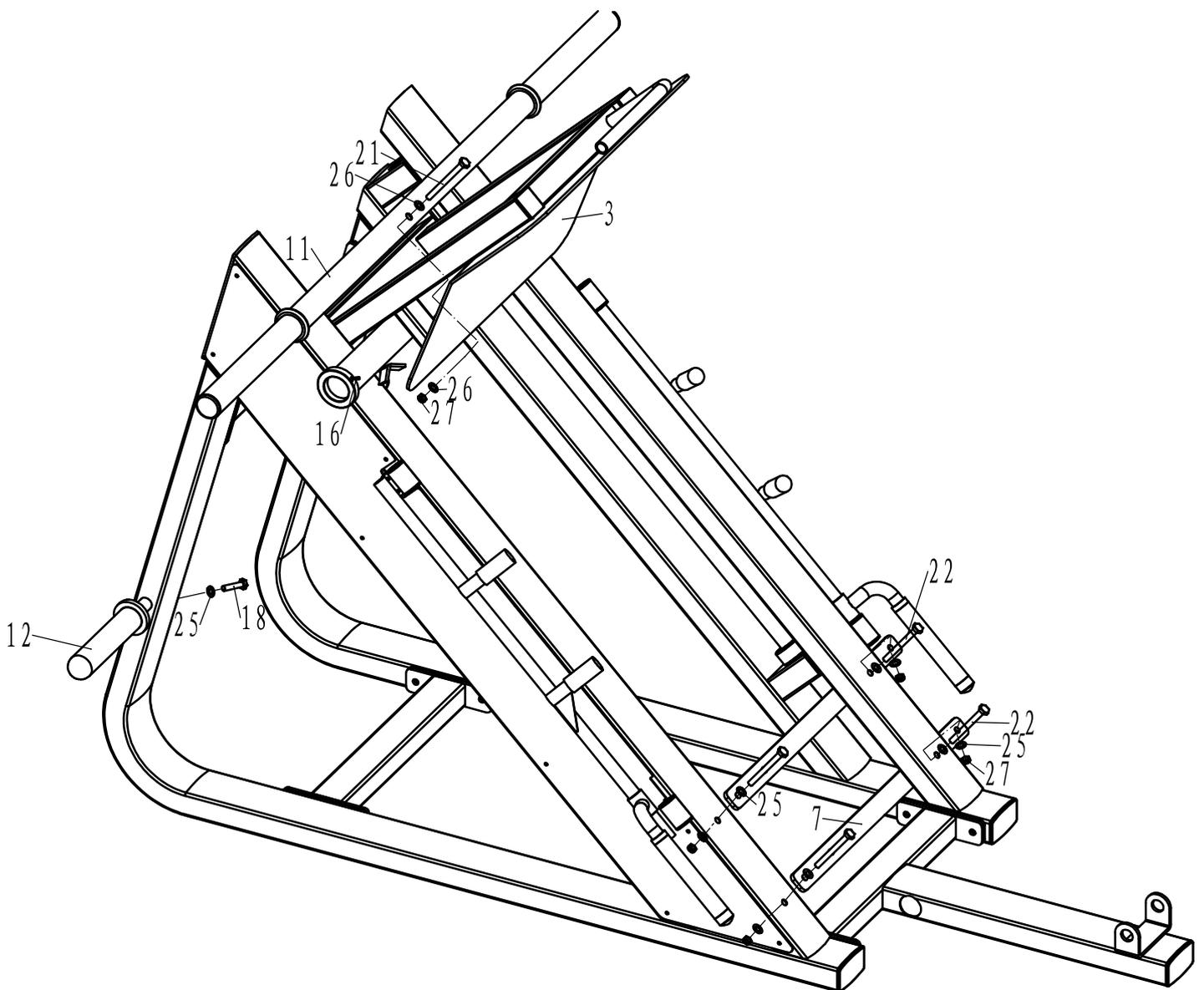

### Step4:

1. Fix Back pad adjusting fix frame6 to Back pad frame contacting frame9 with M10 \* 25 Allen head bolt19 and  $\Phi$  10 Washer25.
2. Fix Back pad frame4 to Back pad frame contacting frame9 with M10 \* 25 Allen head bolt19 and  $\Phi$  10 Washer25.
3. Insert Back pad adjusting frame5 to Back pad frame4.
4. Fix Back pad adjusting frame5 to Back pad frame4 with M10 \* 25 Allen head bolt19 and  $\Phi$  10 Washer25.

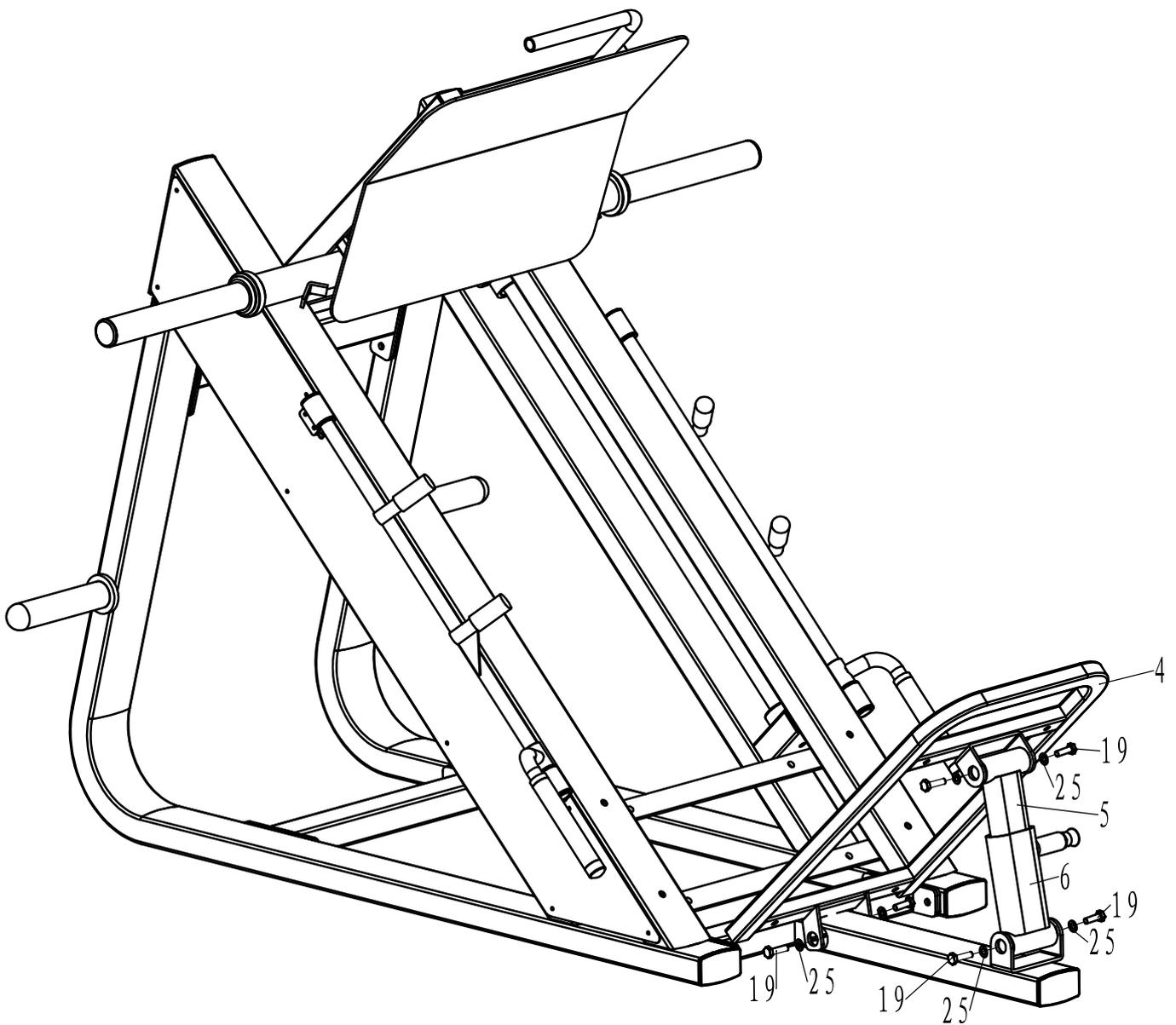

### Step5:

1. Fix Pour kicking back pad13 to Back pad frame4 with M10 \* 40 Allen head bolt20 and  $\Phi 10$  Washer25.
2. Fix Block pad14 to Back pad fixed plate7 with M10 \* 20 Allen head bolt18 and  $\Phi 10$  Washer25.

